

HOBART701 S Ridge Avenue, Troy, OH 45374
1-888-4HOBART • www.hobartcorp.com**HBA1G SINGLE RACK
OVEN – GAS****HOBART****STANDARD FEATURES**

- Advanced digital programmable control panel includes:
 - Bake/steam timers
 - Cool-down mode
 - Four stage baking
 - Auto on/off control
 - Auto vent
 - 99 menus
 - Energy saving idle mode
- 180,000 BTU in-shot burner system
- Heat exchanger with weldless construction for longer life
- Heavy duty rack lift with rack jam warning system utilizing slip clutch feature
- Soft start rotation system
- Stainless steel construction
- Oven body shipped assembled (hood, steam system & floor are field installed)
- Flush floor with patented adjustable floor construction provides easy access – no ramp required
- Field reversible bake chamber door
- Hood with plenum for Type II installation
- Space saving 55" wide x 51" deep footprint (less canopy)
- Patented self-contained cast spherical steam system
- Pre-plumbed water regulator
- Built-in rollers and levelers for ease of installation
- Single point 8" vent connection
- Stainless steel "B" style rack lift
- One year parts/labor warranty

MODEL

- HBA1G** – Single Rack Oven, Gas

OPTIONS AND ACCESSORIES

- Back-up control
- Propane gas
- Floor extender kit
- Oven body shipped split
- Aluminum or stainless steel oven racks
- Hood with grease filters – Type 1 (UL listed to Standard UL 710 and meets all requirements of NFPA-96)
- "C" style rack lift
- Kosher package
- 50 Hz available, consult factory for details

Specifications, Details and Dimensions on Back.

**HBA1G SINGLE RACK OVEN – GAS**

ANSI/NSF Standard #4

City of LA (M-910049) and State of MA (C3-0606-363)

HBA1G SINGLE RACK OVEN – GAS



701 S Ridge Avenue, Troy, OH 45374
1-888-4HOBART • www.hobartcorp.com

SPECIFICATIONS

- Water**— $\frac{1}{2}$ " NPT. Cold water @ 30 psi. minimum @ 2.0 GPM flow rate. Water supply must have the proper hardness, pH and chloride concentration. Consult your local Hobart service office, water company and/or water conditioner dealer before installation. Recommended water hardness range: 2-4 grains per gallon Recommended pH range: 7.0 to 8.0 Acceptable range for chloride concentration: 0-30 ppm
- Drain**—Choose either rear or front drain and plug the drain connection that is not in use. Route to air-gap drain.
Rear drain: $\frac{1}{2}$ " NPTF
Front drain: $\frac{1}{2}$ " NPTM
- Gas Connect Point**— $\frac{3}{4}$ " NPT.
180,000 BTU/HR (51.3 kj/sec)
Natural Gas Input Rate—5" to 14" w.c. (1.25 kPa to 3.50 kPa)
Propane Gas Input Rate—12" to 14" w.c. (3.0 kPa to 3.5 kPa)
- Electrical**—2 supplies required.
 - 120/60/1 15 amps – dedicated circuit required max. 20A
 - 208-230/60/3 4.4-4.2 amps
220/60/1 8.6 amps
460/60/3 2.2 amps
- Hood Vent**—8" diameter connection collar. Minimum 690 cfm (19.5 m³/min) required with 0.6" w.c. (150 Pa) static pressure drop through hood. Customer to supply duct and ventilator fan per local code. Air proving switch factory installed and integrated with burner system operation. Oven provided relay with max. 10.0 amp $\frac{1}{2}$ H.P. @ 120V output for fan operation.

NOTES

- The purchaser is responsible for all installation costs and for providing: Disposal of packing materials; labor to unload oven upon arrival; installation mechanics; and all local service connections including electricity, vents, gas water and drain per local code. A factory technician or factory authorized installation technician must supervise and approve any installation. In order to validate the warranty, the start-up must be performed by an Authorized Servicer.
- All services must comply with federal, state and local codes. Input rates will be reduced when oven installed at elevations over 3,000' (915 m). Consult factory for elevation correction.
- CAUTION** – To reduce the risk of fire, the appliance is to be mounted on floors of non-combustible construction with non-combustible flooring and surface finish and with no combustible material against the underside thereof, or on non-combustible slabs or arches having no combustible material against the underside. **IMPORTANT:** Do not route utilities (wiring, plumbing, etc.) in or under the non-combustible floor beneath the oven.
- For proper installation, floor should be level within $\frac{1}{8}$ " per foot not to exceed $\frac{3}{4}$ ". Floor anchors require minimum of 1" thick solid floor substrate.
- Minimum clearances to combustible construction: 0 inches from sides and back; 18" from top (99.5"). 10 feet minimum ceiling height for service access and tilt up for installation.
- Ventilator fan is required. Consult local authorities to determine whether TYPE 1 (grease) or TYPE 2 (vapor) duct will be required. Hood connection suitable for connection to Type B vent, except when products of baking are grease laden.
- Actual weight: 2,530 lbs.;
Shipping weight: 2,775 lbs. (freight class 70)

SECTION	W x L x H (CRATED)	PALLET WT. (lbs.) / CU. FT.		W x D x H (ACTUAL)
Heating	62" x 108" x 65"	2,555	251.9	55" x 51" x 104"
Hood	23" x 84" x 40"	220	44.8	18" x 55" x 31"
Shipping Total		2,775	296.7	

DETAILS AND DIMENSIONS

Highest Point on Oven—104.0" (264.2 cm)

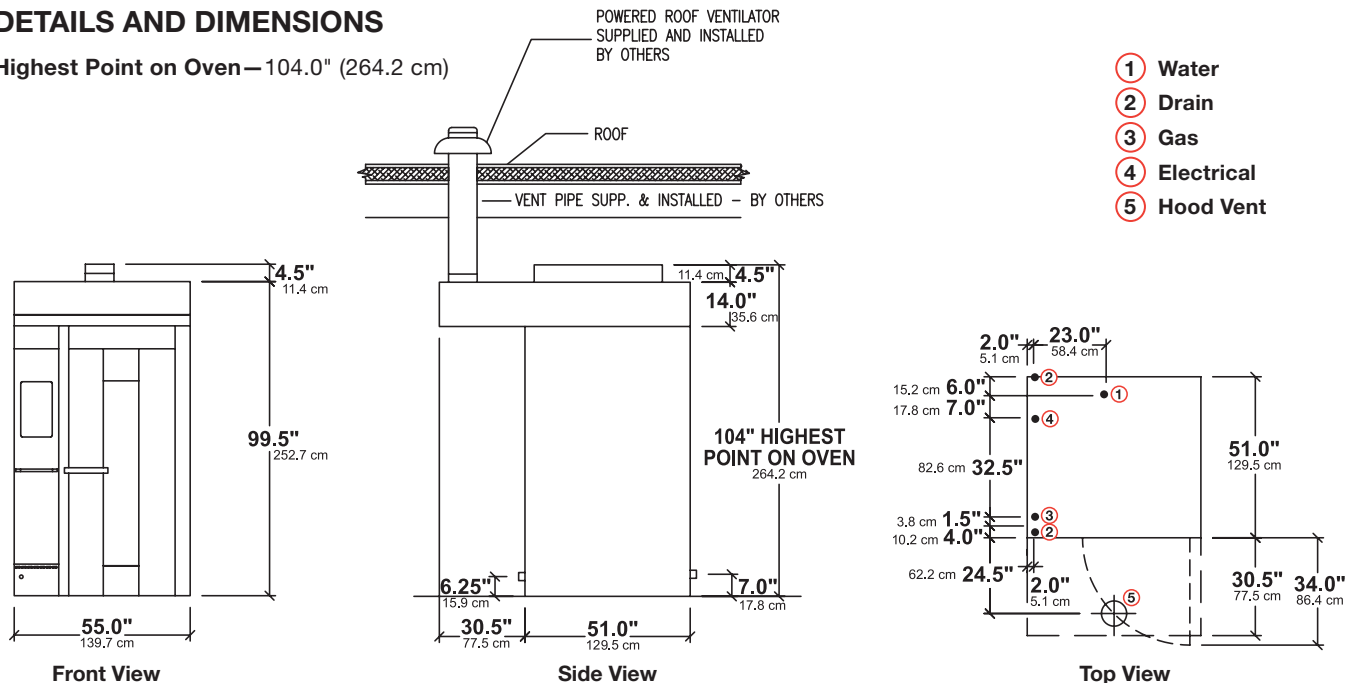

As continued product improvement is a policy of Hobart, specifications are subject to change without notice.